

SSC-N24/N24A

Analog Color Mini-Dome Cameras

SONY
make.believe

650 TV Line Security Camera with High Sensitivity

- Horizontal resolution 650 TV lines
- High sensitivity
Color : 0.15 lx (F1.2, 50 IRE)
B/W : 0.01 lx (F1.2, 50 IRE)
- x3.7 Variable focal lens
- Compact design



KEY FEATURES

- High resolution (650 horizontal TV lines) and high sensitivity (Color : 0.15 lx / B/W : 0.01 lx, F1.2, 50IRE) achieved by a 1/3-type "EXview HAD CCD II" sensor and Sony's new digital signal processor, "Effio-E".

EXview HAD CCD II™

- 3.7x variable focal length lens with a focal length of 2.8 mm to 10.5 mm and a horizontal angle of view of 101.8 ° to 27.4 °.
- Easy and flexible camera angle adjustment achieved by a new three-hinge structure.

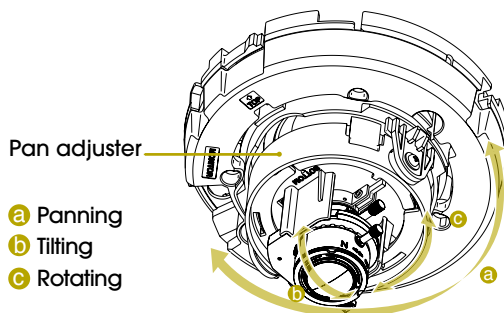

- ATR-Lite (Adaptive Tone Reproduction Lite) to compensate for gradation of subjects to an optimum level.
 - iBLC to compensate for exposure levels in dark scenes to improve subject visibility.
 - ATW (Automatic Tracing White) balance which automatically adjusts the camera's white balance to adapt to sudden changes in lighting conditions.
 - Internal lock, and line lock selectable.
 - 2D noise reduction employed.
 - AC 24 V/DC 12 V operation ($\pm 10\%$).
 - Custom template supplied.
- Optical Day / Night function to switch to Day or Night mode depending on the light level.
 - Low power consumption: 1.7 W (Max.).

SPECIFICATIONS

| | SSC-N24 | SSC-N24A |
|---------------------------------------|---|-------------------------------|
| Camera | | |
| Image device | 1/3-type "EXview HAD CCD II" | |
| Number of effective pixels (H x V) | 570,000 pixels (976 x 582) | 480,000 pixels (976 x 494) |
| Signal system | PAL standard | NTSC standard |
| Horizontal resolution | 650 TV lines | |
| S/N ratio | More than 55 dB(AGC Off) | |
| Minimum illumination | Color: 0.15 lx, B/W: 0.01 lx (F1.2, 50 IRE) Color: 0.08 lx, B/W: 0.003 lx (F1.2, 30 IRE) | |
| Video output | VBS: 1.0Vp-p | |
| Synchronization | Internal/AC line lock selectable | |
| Gain control | Auto (on/off) | |
| White balance | ATW (2000K to 10000K), ATW-PRO (2500K to 6000K) | |
| Lens type | Built-in variable focal lens | |
| Zoom ratio | Optical 3.7X | |
| Horizontal viewing angle | 101.8 degree to 27.4 degree | |
| Focal length | f=2.8 to 10.5 mm | |
| F Number | F1.2(Wide end), F2.6(Tele end) | |
| Minimum object distance | 300 mm | |
| Iris | Auto | |
| Panning range | 355 degree | |
| Tilting range | ±77 degree | |
| Swivel rotation | 350 degree | |
| Camera Features | | |
| Day/Night | Yes | |
| Noise reduction | Yes (2D NR) | |
| Back light compensation | Yes (iBLC) | |
| Automatic tone reproduction | Yes (ATR-Lite) | |
| General | | |
| Mass | 320 g (11.3 oz) | |
| Dimensions | ø121.6 mm x 86.5 mm (ø 4 7/8 x 3 1/2 inches) | |
| Power requirement | AC24 V ±10%, DC12 V ±10% | |
| Power consumption | Max. 1.7 W | |
| Operating temperature | -10°C to +50°C (14F° to 122F°) | |
| Storage temperature | -40 °C to +60 °C (-40F° to +140F°) | |
| Operating humidity | 20 % to 80 % | |
| Storage humidity | 20 % to 95 % | |
| Supplied accessories | Template x 1, Operating instructions x 1 | |

DIMENSIONS

Unit: mm (inches)

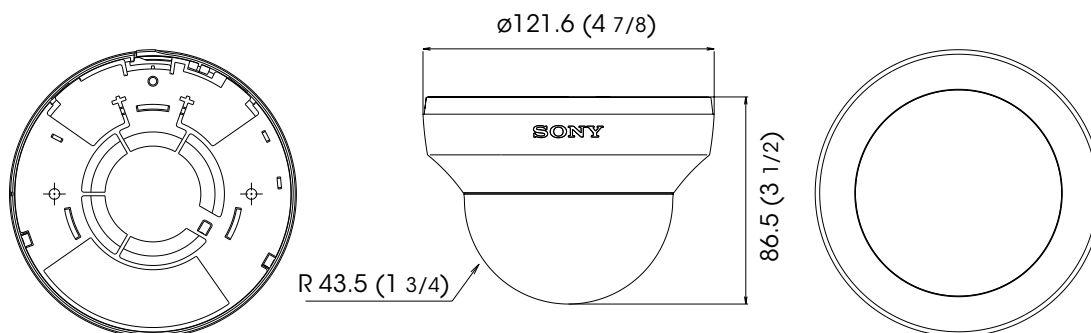

Distributed by

© 2011 Sony Corporation. All rights reserved.
 Reproduction in whole or in part without written permission is prohibited.
 Features and specifications are subject to change without notice.
 The values for weight and dimension are approximate.
 "SONY", "make.believe", "Effio-E" and "EXview HAD CCD II"
 are trademarks of Sony Corporation.
 All other trademarks are the property of their respective owners.